

User and Installation
Guide

iFinity)))™ Digital Wireless

Audio Receiver

Amphony®





LEGAL LIMITATIONS

REPLACEMENT AS PROVIDED UNDER THIS WARRANTY IS YOUR EXCLUSIVE REMEDY. WE SHALL NOT BE HELD LIABLE FOR ANY INCIDENTAL OR CONSEQUENTIAL DAMAGES FOR BREACH OF ANY EXPRESSED OR IMPLIED WARRANTY ON THIS EQUIPMENT, NOR FOR ANY INCIDENTAL OR CONSEQUENTIAL DAMAGES RESULTING FROM THE USE OF, OR INABILITY TO USE, THIS EQUIPMENT. UNDER NO CIRCUMSTANCES SHALL OUR LIABILITY, IF ANY, EXCEED THE PURCHASE PRICE PAID FOR THIS EQUIPMENT, EXCEPT TO THE EXTENT PROHIBITED BY APPLICABLE LAW. EXCEPT AS PROVIDED HEREIN, WE MAKE NO WARRANTIES, EXPRESS OR IMPLIED, INCLUDING WARRANTIES OF MERCHANTABILITY AND FITNESS FOR A PARTICULAR PURPOSE. WE RESERVE THE RIGHT TO REFUSE TO HONOR THIS WARRANTY IF WE DETERMINE ANY OF THE ABOVE EXCEPTIONS TO HAVE CAUSED THIS EQUIPMENT NOT TO HAVE PERFORMED PROPERLY. THIS WARRANTY SHALL BE VOID IF ANY FACTORY-APPLIED IDENTIFICATION MARK, INCLUDING BUT NOT LIMITED TO SERIAL NUMBERS AND WARRANTY LABELS, HAS BEEN ALTERED OR REMOVED. THIS WARRANTY SHALL ALSO BE VOID IF THE TRANSMITTER OR AMPLIFIER HAVE BEEN OPENED BY AN UNAUTHORIZED PERSON.

This warranty gives you specific legal rights which may vary from state to state. Some states do not allow the exclusion or limitation of incidental or consequential damages, or allow limitations on the duration of an implied warranty, so those limitations may not apply to you.

Note: No responsibility is assumed for the presence of interference outside of Amphony's control, such as other transmitters or cordless phones, which may hamper proper signal reception.



Contents

Unpacking	3
Selecting the audio channels	3
Connecting the receiver	4
Placing the receiver	6
Troubleshooting	7
Technical specifications	9
Safety information	10
Limited Warranty	12



Note: This product requires an iFinity Audio Transmitter for operation (not included).

Unpacking: Check that this package contains:

One iFinity Wireless Audio receiver, one 9 V AC adapter (wallwart), one dual RCA cable.

Step 1 Connecting the receiver

Connect the DC power input of the receiver with the supplied 9 V AC adapter (wallwart). Connect the receiver to active loudspeakers, active subwoofers or an audio amplifier via the supplied RCA audio cable.

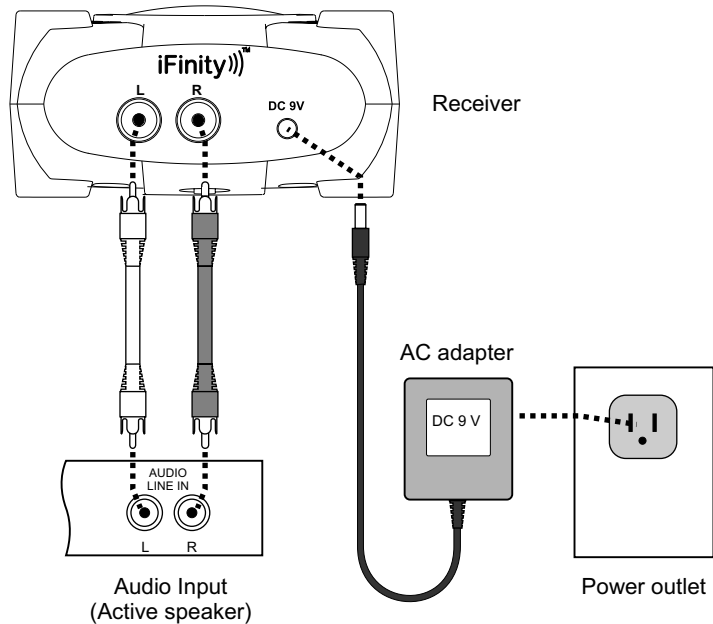

Limited warranty

WHAT YOUR WARRANTY COVERS

This warranty extends only to the original user of the equipment ("you", "your") and is limited to the purchase price of each part. Amphony and its affiliated companies ("we", "our", "us") warrant this Wireless Audio Receiver against defects in materials or workmanship as follows.

LABOR: For a period of ninety (90) days from the original date of purchase, if we determine that the equipment is defective subject to the limitations of this warranty, we will replace it at no charge for labor. We warrant any such work done against defects in materials or workmanship for the remaining portion of the original warranty period.

PARTS: For a period of one (1) year from the original date of purchase, we will supply, at no charge, new or rebuilt replacement parts in exchange for parts we determine are defective subject to the limitations of this warranty. We warrant any such replacement parts against defects in materials or workmanship for the remaining portion of the original warranty period.

Note: "Parts" means items included in this package. It does *not* include other parts purchased separately.

WHAT YOUR WARRANTY DOES NOT COVER

This warranty *does not cover* consumer instruction, physical setup or adjustment of any consumer electronic equipment, or signal transmission problems.

This warranty *does not cover* cosmetic damage, damage due to the affixing of any attachment not provided with the product, loss of parts, connecting the product to any but the specified receptacles, lightning, electrical surges, fire, flood, or other acts of God, accident, misuse, abuse, repair or alteration by other than authorized service personnel, negligence, commercial or institutional use, or improper or neglected maintenance.

This warranty *does not cover* equipment sold AS IS or WITH ALL FAULTS, equipment removal or reinstallation, shipping damage if the equipment was not packed and shipped in the manner we prescribe, nor equipment purchased, serviced, or operated outside the contiguous United States of America.





NON-USE PERIODS

- When the product is not being used for a long period of time, unplug the product.

CLEANING

- Unplug the product before cleaning.
- When the system gets dirty, wipe it with a clean, soft cloth. If necessary, wipe it with a soft cloth, slightly dampened with soapy water. Wipe dry immediately with a dry cloth.
- Never use benzene, aerosol cleaners, thinner, alcohol or any volatile cleaning agent.
- Do not use abrasive cleaners, as they may damage the finish.

SERVICE

- Do not open the cabinet of any components. Opening the cabinets may present a shock hazard, and any modification to this product will void your warranty.
- Do not attempt to service the unit yourself.



Step 2 Pairing the receiver with the transmitter

In order to receive audio, the receiver must first be paired with your iFinity audio transmitter.

Press the pairing button of your iFinity transmitter (please refer to your iFinity transmitter user manual for further details). The transmitter network status light will start flashing quickly.

Press the pairing button of your iFinity wireless audio receiver within 5 minutes. This button is located at the bottom of the receiver (please see picture on next page). Once the receiver locks to the transmitter signal, the receiver network status light will light continuously. You now should be able to hear the audio.

You can pair up to 4 wireless receivers with one transmitter. Pair each wireless receiver as shown above.

Description of the receiver network status light

Flashing Slowly: Not paired to any transmitter signal

Flashing Quickly: Pairing Mode

Always On: Audio is being received



Do not connect the receiver to passive speakers! Use the Model 480 Wireless Audio amplifier to connect to passive speakers.



Receiver bottom view

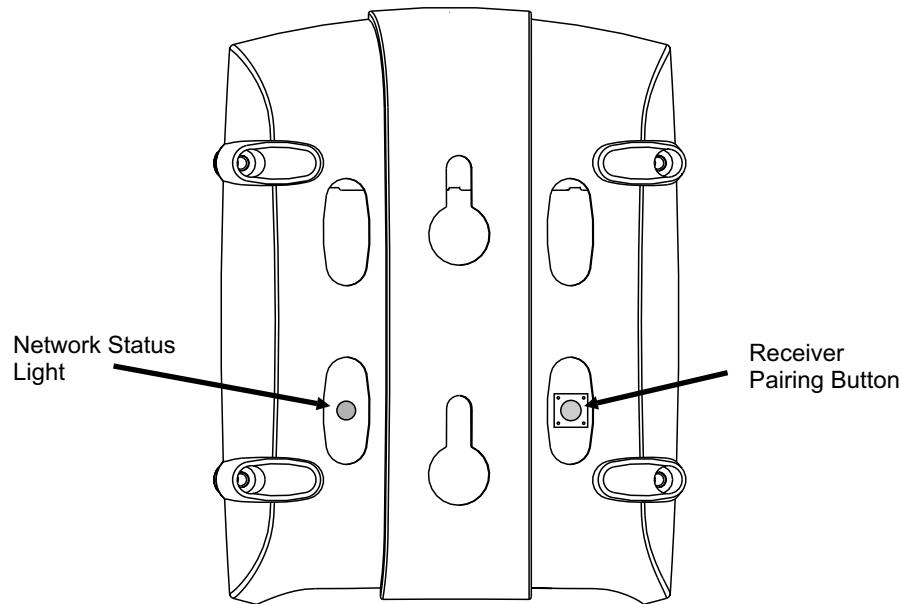

IMPORTANT SAFETY INFORMATION

ATTENTION!



READ THESE SAFETY INSTRUCTIONS CAREFULLY AND HEED ALL WARNINGS IN THIS MANUAL.

POWER SOURCE

To product malfunction, and to protect against electric shock, fire or personal injury, please observe the following:

- This product has been designed to work with 120-volt AC current using the supplied AC adapters. Connection to a line voltage other than that or use of non-compatible AC adapters may create a safety and fire hazard and may damage the product.
- Do not run power cords under rugs or carpets or place heavy objects on them.
- Damaged or deformed power cords are hazardous and should be replaced immediately by a qualified service technician.

LOCATION

- Do not use this product outdoors or in cars.
- Do not place this product in direct sunlight, or near heat sources.
- Keep this product away from strong magnetic objects.

VOLUME CONTROL

- Do not turn up the transmitter volume while listening to a portion with very low level input or no audio signal to avoid damage to your speakers during a peak level audio portion.
- Turn the transmitter volume control to minimum prior to connecting or disconnecting the transmitter or receiver and prior to switching audio sources as this may cause loud clicks which can damage your speakers.

CARE

- Do not place any object containing water or other liquids on this product.
- Do not remove the cabinet. Touching parts inside the cabinet could result in electric shock and damage to the product.



Copyright (C) 2012 Amphony. All rights reserved.

The information contained herein is subject to change without notice. Revisions may be issued to advise of such changes and/or additions.

All product names, trade names, or corporate names mentioned in this document are acknowledged to be the proprietary property of the registered owners.

FCC ID: PMJRX1

This device complies with part 15 of the FCC Rules. Operation is subjected to the following two conditions: 1) This device may not cause harmful interference and 2) this device must accept any interference received, including interference that may cause undesired operation.

Caution: Any changes or modifications not expressly approved by the party responsible for compliance could void the user's authority to operate the equipment.

Troubleshooting

Problem	Possible Cause	Solution
No audio at receiver	No wireless signal	Check that your iFinity transmitter is plugged in.
	Receiver not paired	Pair the receiver with your iFinity transmitter.
	Faulty AC adapter or faulty power outlet	Check the receiver power supply.
	Strong interference	See under "Strong Interference" on next page.
	Audio volume too low	See below under "Audio volume too low".
Audio is distorted	Strong interference	See under "Strong Interference" on next page.
Receiver audio level is too low	Audio volume too low	Connect transmitter to an adjustable audio output
	Transmitter volume control set too low	Adjust the transmitter volume control to achieve desired audio level.
Audio drops out intermittently or crackles	Strong interference	See under "Strong Interference" on next page.
	Unstable power supply	See under "Unstable power supply" below.
Audio drops out intermittently or crackles	Strong interference	See under "Strong Interference" on next page.
	Unstable power supply	Ensure that the power outlet delivers a stable voltage. Very strong surges or voltage fluctuations may cause audio dropouts. Try using a surge protector.



Problem	Possible Cause	Solution
Transmitter range is extremely short	Strong interference	In some cases, there may be strong interference preventing proper reception of the audio signal which can be caused by wireless networks or cordless phones. Either eliminate the interference, locate the base unit of the cordless phone in another room, set the wireless network to use the 5.8 GHz frequency band rather than 2.4 GHz, relocate the transmitter, relocate or reorient the receiver to improve reception. Also, try to lower the power output of your wireless LAN router.
	Too many obstacles	Audio will drop out if there are too many obstacles between the transmitter and the receiver, try relocating the transmitter or receiver to improve reception.
Transmitter affects wireless LAN speed	iFinity Transmitter or Receiver too close to wireless LAN device	Increase the distance between the iFinity transmitter or iFinity receiver and your wireless LAN router.

For up-to-date troubleshooting advice, visit www.amphony.com

Technical Specifications:

Output level: **1 Vrms**

Frequency response: **2 Hz ... 20 kHz**

Number of wireless audio channels: **4**

Signal-to-noise ratio: **typ. 91 dB (A weighted)**

Total harmonic distortion: **typ. -90 dB**

Channel separation: **typ. 90 dB**

